

### ATTENZIONE - ATTENTION - ACHTUNG

- Su macchine MX1600ST e MX2100ST solo i motorizzati H=85 arrivano a centro mandrino
- The driven tools with H=85 reach the spindle axis only on lathes MX1600ST and MX2100ST
- Auf MX1600ST und MX2100ST Maschinen erreichen nur die angetriebenen Werkzeugen mit H=85 das Zentrum der Spindel

### ATTENZIONE - ATTENTION - ACHTUNG

- Per lo smontaggio degli utensili utilizzare sempre la chiave di contrasto come indicato nel manuale d'uso.
- For disassembly of the tools use always the contrast key as mentioned in the user instructions.
- Fuer das Abmontieren der Werkzeuge immer den Gegenschlüssel benutzen wie in der Bedienungsanleitung erwaeht.

### ATTENZIONE - ATTENTION - ACHTUNG

- PRIMA DI UTILIZZARE IL MOTORIZZATO CONSULTARE LE ISTRUZIONI ALLEGATE!
- BEFORE USING THE DRIVEN TOOL, PLEASE CHECK THE ENCLOSED INSTRUCTION SHEET!
- VOR DER BENUTZUNG DES ANGETRIEBENEN WERKZEUGES, DIE BEILIEGENDEN INSTRUKTIONEN DURCHLESEN!

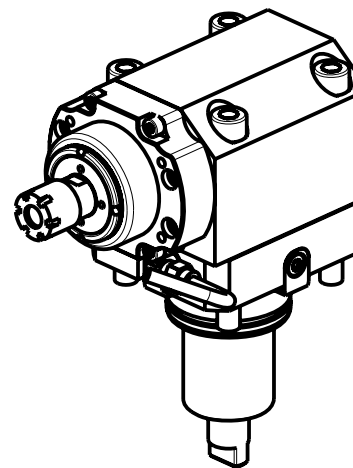
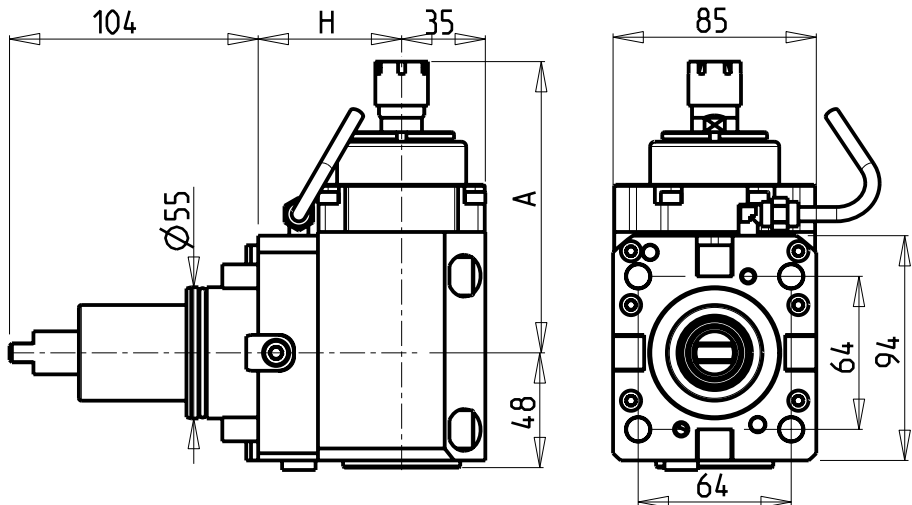

Cod. MT	Cod. DAEWOO	Mandrino Spindle Spindel	I	RPM MAX	Reversibile lato mandrino/contromandrino Reversible sub/main spindle side Umkehrbare Spindel-seite/ Gegenspindel-seite	Lubrificazione int. Coolant through Innenkuehlung	Lubrificazione est. Ext. coolant Aussenkuehlung	A	H	CHIAVI INCLUSE Keys included Schlüssel einbegriffen		
DW00190116	-	ER16	1:5.625	22500	X		X	121.8	60	CHMNER16	CHUB17	
DW00190111	-	ER11	1:5.625	22500	X	P=70bar		134	60	CHMNER11	CHUB11	
DW00190316	-	ER16	1:5.625	22500	X		X	121.8	70	CHMNER16	CHUB17	NEW
DW00190311	-	ER11	1:5.625	22500	X	P=70bar		134	70	CHMNER11	CHUB11	NEW
DW00190216	-	ER16	1:5.625	22500	X		X	121.8	85	CHMNER16	CHUB17	NEW
DW00190211	-	ER11	1:5.625	22500	X	P=70bar		134	85	CHMNER11	CHUB11	NEW

### DAEWOO BMT 55

MOD: PUMA 230-240M/MS-280LM - PUMA 1500-2000-2500M/MS/Y/SY - PUMA TT1500-TT1800MS/SY  
PUMA TL2000-2500 (M) - MX1600/2100TS

MODULO MOTORIZ. ASSIALE MOLTIPLICATO I = 1:5.625

Geared-up axial driven tool I=1:5.625

Axial angetriebenes Werkzeug uebersetzt I=1:5.625

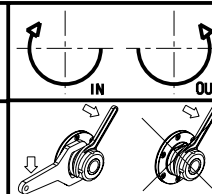

### M.T. srl

Via dei Tamerici 1/3  
Tel. 0541/956034-957884  
Fax 0541/956341

47842 S. GIOVANNI, IN M. (RN)  
e-mail: mima@mlmarchetti.com  
http://www.mlmarchetti.com

PRODUZIONE MODULI ROTANTI



PAGINA DW0210-2-10