

ATTENZIONE - ATTENTION - ACHTUNG

- Su macchine MX1600ST e MX2100ST solo i motorizzati H=85 arrivano a centro mandrino
- The driven tools with H=85 reach the spindle axis only on lathes MX1600ST and MX2100ST
- Auf MX1600ST und MX2100ST Maschinen erreichen nur die angetriebenen Werkzeugen mit H=85 das Zentrum der Spindel

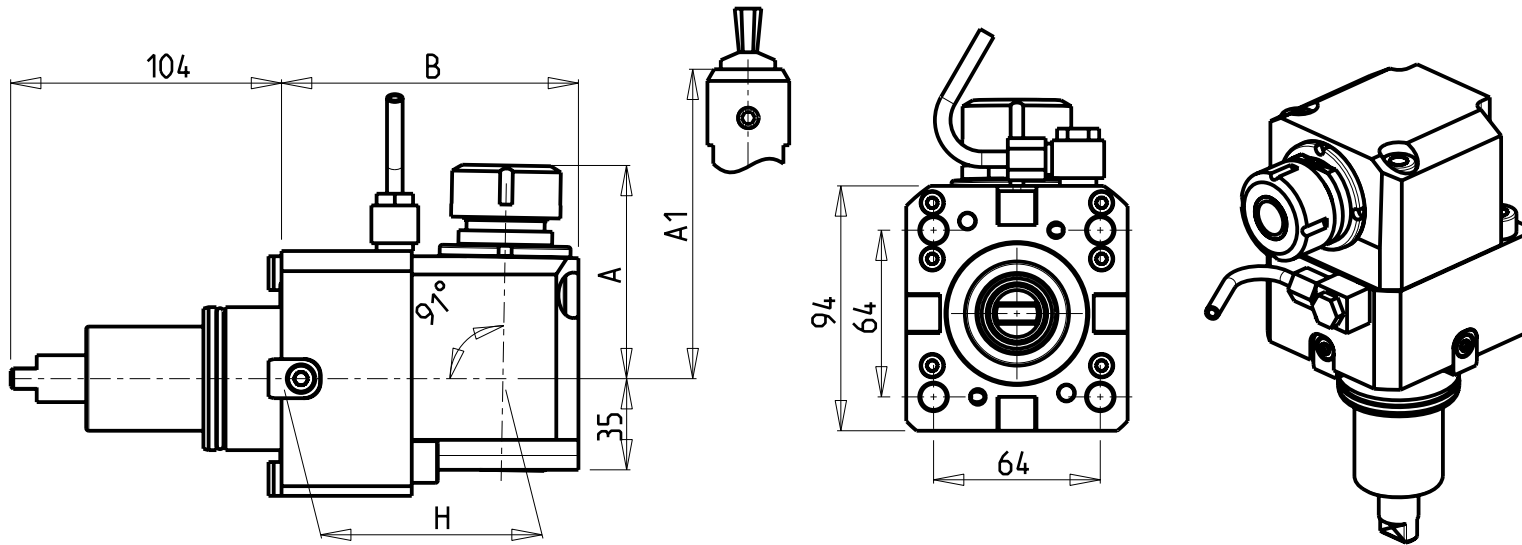

Cod. MT	Cod. DAEWOO	Mandrino Spindel Spindel	I	RPM	Reversibile lato mandrino/contromandrino Reversible sub/main spindle side Umkehrbare Spindel-seite/ Gegenspindel-seite	Lubrificazione int. Coolant through Innenkuehlung	Lubrificazione est. Ext. coolant Aussenkuehlung	A	A1	B	H	CHIAVI NON INCLUSE Keys not included Schlüssel nicht einbegriffen	
0319125	-	ER25	1:1	6000	X		X	81.84	-	89	60	CHSTER25	CHUB36 o 0100000
0319108	-	WELDON 8	1:1	6000	X		X	-	76.5	89	60		
0319110	-	WELDON 10	1:1	6000	X		X	-	76.5	89	60		
0319112	-	WELDON 12	1:1	6000	X		X	-	76.5	89	60		
0319116	-	WELDON 16	1:1	6000	X		X	-	73.7	89	60		
DW 00029125	-	ER25	1:1	6000	X		X	81.84	-	114	85	CHSTER25	CHUB36 o 0100000
DW 00029108	-	WELDON 8	1:1	6000	X		X	-	76.5	114	85		
DW 00029110	-	WELDON 10	1:1	6000	X		X	-	76.5	114	85		
DW 00029112	-	WELDON 12	1:1	6000	X		X	-	76.5	114	85		
DW 00029116	-	WELDON 16	1:1	6000	X		X	-	73.5	114	85		

NEW
NEW
NEW
NEW
NEW

DAEWOO BMT 55

MOD: PUMA 230-240M/MS-280LM - PUMA 1500-2000-2500M/MS/Y/SY - PUMA TT1500-TT1800MS/SY
PUMA TL2000-2500 (M) - MX1600/2100TS

MODULO MOTOR. ASSIALE PER POLIGONATURA INTERNA

Axial driven tool for internal polygon-making

Axial angetriebenes Werkzeug fuer interne Facettierung

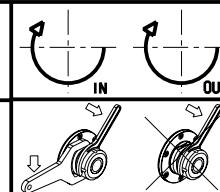

M.T. srl

Via dei Tamerici 1/3
Tel. 0541/956034-957884
Fax 0541/956341
47842 S. GIOVANNI IN M. (RN)
e-mail: mtma@mtmarchetti.com
http://www.mtmarchetti.com

PRODUZIONE MODULI ROTANTI



PAGINA DW 0230-2-10