

ATTENZIONE - ATTENTION - ACHTUNG

-Su macchine PUMA 280, PUMA TT1500-TT1800 serie non arriva in centro mandrino.

-On machines PUMA 280, PUMA TT1500-TT1800 series tool does not get to the centre of the spindle axis.

-Auf Maschinen PUMA 280, PUMA TT1500-TT1800 serie erreicht das Werkzeug nicht die Mitte der Werkzeug-Achse.

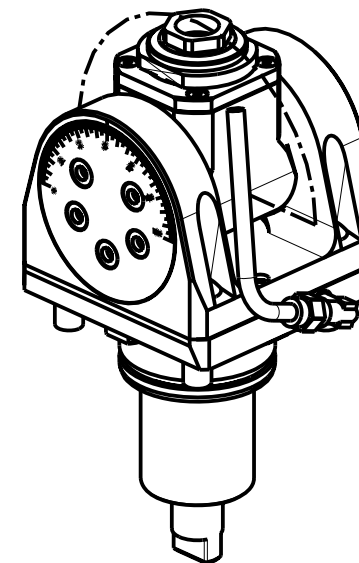

Cod. MT	Cod. DAEW00	Mandrino Spindle Spindel	I	RPM	Reversibile lato mandrino/contromandrino Reversible sub/main spindle side Umkehrbare Spindel-seite/ Gegenspindel-seite	Lubrificazione int. Coolant through Innenkuehlung	Lubrificazione est. Ext. coolant Aussenkuehlung	Dmax	Dmin	CHIAVI INCLUSE Keys included Schlüssel inbegriffen			
0860120	-	ER A 20	1:1	6000	X		X	13	1	CHUB22	CHUB36	CHESL08	NEW

DAEW00 BMT 55

MOD: PUMA 230-240M/MS-280LM - PUMA 1500-2000-2500M/MS/Y/SY - PUMA TT1500-TT1800MS/SY - TL2000-2500 (M)

MODULO MOTORIZZATO ORIENTABILE ERA20 ±90° H=47.5

±90° adjustable angle driven tool ERA20 H=47.5

Angetriebenes Werkzeug schwenkbar ±90° ERA20 H=47.5

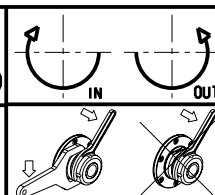

M.T. srl

Via dei Tamerici 1/3
Tel. 0541/956034-957884

Fax 0541/956341

47842 S. GIOVANNI IN M. (RN)

e-mail: mima@mtmarchetti.com

http://www.mtmarchetti.com

PRODUZIONE MODULI ROTANTI



PAGINA DW 0335-2-00