

ATTENZIONE - ATTENTION - ACHTUNG
 Su macchine TT2000SY-TT2500SY-TT2500MS - MX2000ST - MX2500LT/ST/LST
 non arriva in centro mandrino.
 On machines TT2000SY-TT2500SY-TT2500MS - MX2000ST - MX2500LT/ST/LST
 tool does not get to the centre of the spindle axis.
 Auf Maschinen TT2000SY-TT2500SY-TT2500MS - MX2000ST - MX2500LT/ST/LST
 erreicht das Werkzeug nicht die Mitte der Werkzeug-Achse.

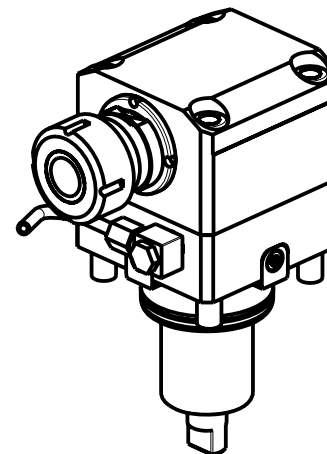

- Chiave inclusa
- Key included
- Schluessel inbegriffen

Cod. MT	Cod. EPPINGER	Mandrino Spindle Spindel	I	RPM	Reversibile lato mandrino/contromandrino Reversible sub/main spindle side Umkehrbare Spindel-seite/ Gegenspindel-seite	Lubr.interna Coolant through Innenkuehlung	Lubr.esterna Ext. coolant Aussenkuehlung	A	A1	A2	B	D	L	CHIAVI NON INCLUDE Keys not included Schluessel nicht einbegriffen	
														CHSTER32	CHUB36
0321432	7.070.678	ER32	1:1	6000	X		X	98.16	-	-	47	-	-	CHSTER32	CHUB36
0321032	-	ER32	1:1	6000	X	P=18bar	X	98.16	-	-	79	-	-	CHSTER32	CHUB36
0320022	-	WELDON 20	1:1	6000	X		X	-	-	100	47	-	-		
0321617	-	Ø16x17	1:1	6000	X		X	-	61	-	47	16	17	CH_VTCROCE_M08 •	CHUB36
0322219	-	Ø22x19	1:1	6000	X		X	-	62	-	47	22	19	CH_VTCROCE_M10 •	CHUB36
0322240	-	Ø22x40	1:1	6000	X		X	-	62	-	47	22	40	CH_VTCROCE_M10 •	CHUB36
0322721	-	Ø27x21	1:1	6000	X		X	-	64	-	47	27	21	CH_VTCROCE_M12 •	CHUB36
0322733	-	Ø27x33	1:1	6000	X		X	-	64	-	47	27	33	CH_VTCROCE_M12 •	CHUB36
0322750	-	Ø27x50	1:1	6000	X		X	-	64	-	47	27	50	CH_VTCROCE_M12 •	CHUB36

DAEWOO BMT 65

MOD: PUMA 300M/MS - V400M - TT2000SY-TT2500SY-TT2500MS - MX2000ST - MX2500LT/ST/LST - PUMA INVERTURN 3000M

MODULO MOTORIZZATO ASSIALE

Axial driven tool

Axial angetriebenes Werkzeug

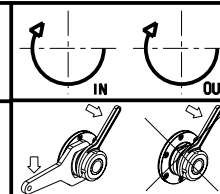

M.T. srl

Via dei Tamerici 1/3
 Tel. 0541/956034-957884

Fax 0541/956341

47842 S. GIOVANNI IN M. (RN)

e-mail: mima@mtmarchetti.com

http://www.mtmarchetti.com

PRODUZIONE MODULI ROTANTI



PAGINA DW 0150-3-10