

L'UTENSILE LAMA PUO' ESSERE MONTATO SUL LATO DX
O SUL LATO SX PER TAGLIARE A ZERO SIA SUL MANDRINO
PRINCIPALE CHE SUL CONTROMANDRINO

POSSIBILITA' DI LAVORO M3/M4
OPTION OF M3/M4 WORKING
ARBEITSMÖGLICHKEIT M3/M4

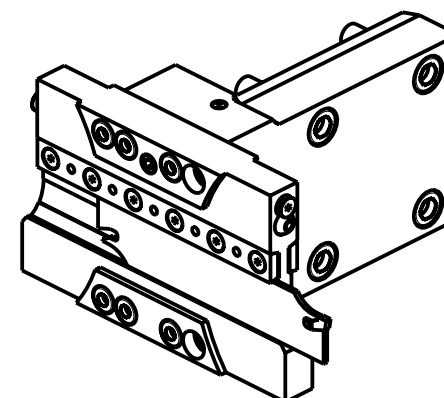

DOTAZIONI - SUPPLIED WITH - AUSSTATTUNG

- N°1 - LAMA - BLADE - KLINGE ISCAR H=32 Sp. 3/4/5mm (KENNAMETAL OPTIONAL)
- N°10 - INSERTI - INSERTS - EINLAGEN
- N°1 - CHIAVE A T PER MONTAGGIO INSERTI
- T-WRENCH FOR INSERT SET UP
- T-SCHLUESSEL FUER EINSATZSTUECK-MONTAGE

Cod. MT	Cod. EPPINGER	N°Utensili N°Tools N°Werkzeuge	Consente taglio a filo lato mandrino e contromandrino This allows for close up cutting off on main and sub-spindle side Ermöglicht Beschnitt Spindel und Gegenspindel-seite
DW 00120132	-	1	X

DAEW00 BMT 65

MOD: PUMA 300M/MS - V400M - TT2000SY-TT2500SY-TT2500MS - MX2000ST - MX2500LT/ST/LST - PUMA INVERTURN 3000M

PORTAUTENSILE PER LAMA DOPPIO

Radial double blade holder

Radial Doppel-Abstechhalter

M.T. srl

Via dei Tamerici 1/3
Tel. 0541/956034-957884
Fax 0541/956341
47842 S. GIOVANNI IN M. (RN)
e-mail: mima@mlmarchetti.com
http://www.mlmarchetti.com

PRODUZIONE MODULI ROTANTI



PAGINA DW 0520-3-00