

**ATTENZIONE - ATTENTION - ACHTUNG**

- Per lo smontaggio degli utensili utilizzare sempre la chiave di contrasto come indicato nel manuale d'uso.
- For disassembly of the tools use always the contrast key as mentioned in the user instructions.
- Fuer das Abmontieren der Werkzeuge immer den Gegenschlüssel benutzen wie in der Bedienungsanleitung erwaeht.

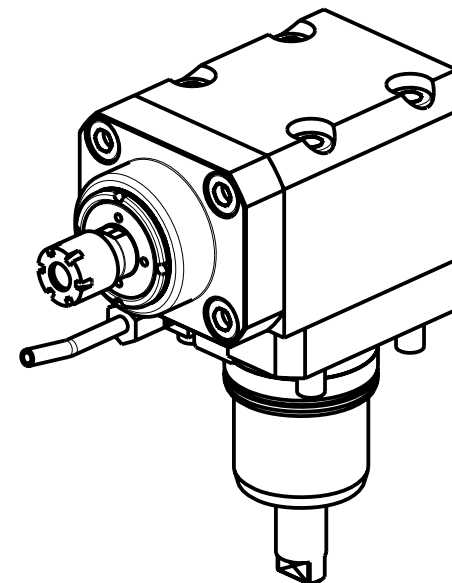

**ATTENZIONE - ATTENTION - ACHTUNG**

- PRIMA DI UTILIZZARE IL MOTORIZZATO CONSULTARE LE ISTRUZIONI ALLEGATE!
- BEFORE USING THE DRIVEN TOOL, PLEASE CHECK THE ENCLOSED INSTRUCTION SHEET!
- VOR DER BENUTZUNG DES ANGETRIEBENEN WERKZEUGES, DIE BEILIEGENDEN INSTRUKTIONEN DURCHLESEN!

Cod. MT	Cod. NAKAMURA	Mandrino Spindle	I	RPM	Reversibile lato mandrino/contromandrino Reversible sub/main spindle side Umkehrbare Spindel-seite/ Gegenspindel-seite	Lubrificazione int. Coolant through Innenkuehlung	Lubrificazione est. Ext. coolant Aussenkuehlung	CHIAVI INCLUSE Keys included Schluesssel einbegriffen	
NKM0050016	-	ER16	1:3	18000	X		X	CHUB17	CHMNER16

**NAKAMURA-TOME**

MOD: WT150/250 - WTW150 - WTS150 - NTM3 - SUPER NTJ - SC250

MOD: TW10M/MY/MM/MMY/MYY-TW20M/MY/MM/MMY/MYY 16 ST.

MODULO MOTOR. ASSIALE MOLTIPLICATO INT. 55 mm I=1:3

Geared-up axial driven tool with 55mm interaxis I=1:3

Axial angetriebenes Werkzeug uebersetzt int. 55 mm I=1:3

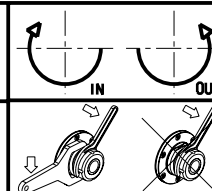

**M.T. srl**

Via dei Tamerici 1/3  
Tel. 0541/956034-957884

Fax 0541/956341

47842 S. GIOVANNI IN M. (RN)

e-mail: mima@mtmarchetti.com

http://www.mtmarchetti.com

PRODUZIONE MODULI ROTANTI



PAGINA NKM205-2-10