

ATTENZIONE - ATTENTION - ACHTUNG

- Per lo smontaggio degli utensili utilizzare sempre la chiave di contrasto come indicato nel manuale d'uso.
- For disassembly of the tools use always the contrast key as mentioned in the user instructions.
- Fuer das Abmontieren der Werkzeuge immer den Gegenschlüssel benutzen wie in der Bedienungsanleitung erwäehnt.

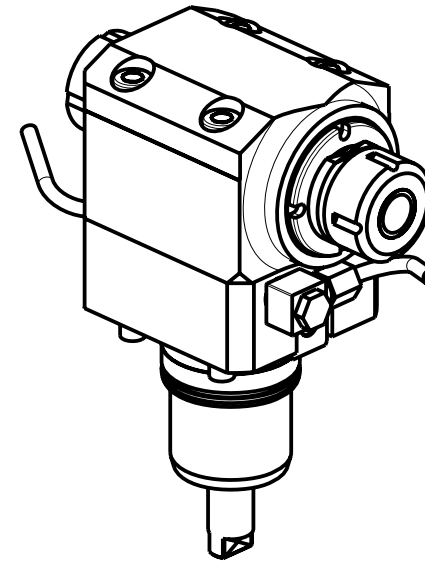
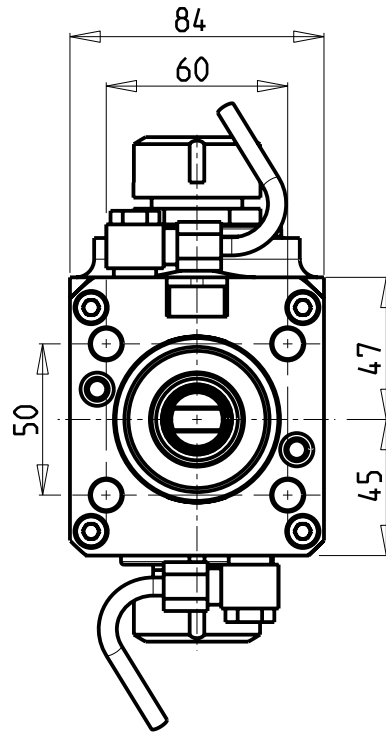
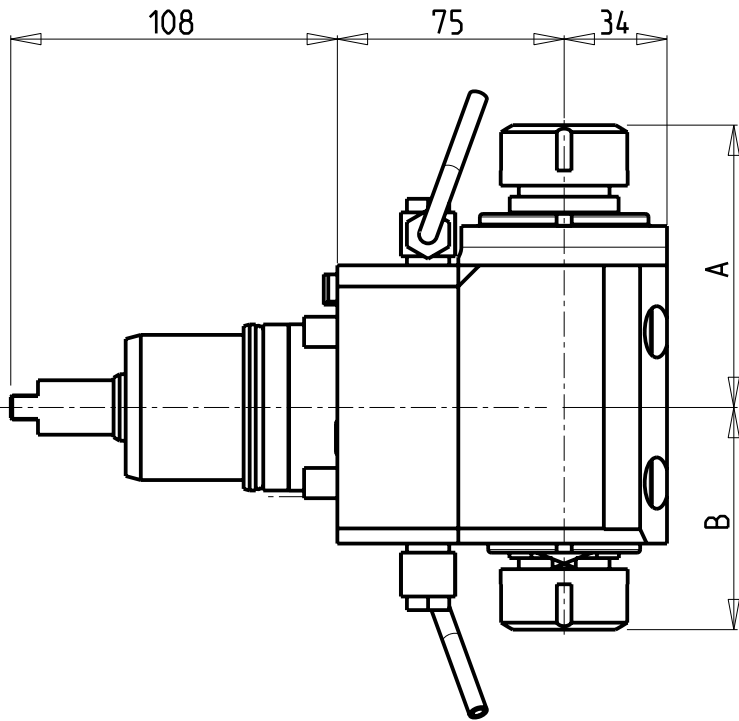

Cod. MT	Cod. NAKAMURA	Mandrino Spindle Spindel	I	RPM	Reversibile lato mandrino/contromandrino Reversible sub/main spindle side Umkehrbare Spindel-seite/ Gegenspindel-seite	Lubrificazione int. Coolant through Innenkuehlung	Lubrificazione est. Ext. coolant Aussenkuehlung	A	B	CHIAVI NON INCLUSE Keys not included Schlüssel nicht einbegriffen		NEW NEW
										CHSTER25	CHUB36+CHUB29	
NKM0502525	-	ER25+ER25	1:1	6000	X		X	93.36	73.46	CHSTER25	CHUB36+CHUB29	
NKM0503232	-	ER32+ER32	1:1	6000	X		X	100.56	78.96	CHSTER32	CHUB36	

NAKAMURA-TOME

MOD:WT250 - WTW150 - WTS150 - SC250 - SUPER NTJX

MODULO MOTORIZZATO ASSIALE BISPORGENTE H=75

Opposite face axial driven tool with 75 mm interaxis

Axial angetriebenes Werkzeug halb vorspringend int. 75 mm

M.T. srl

Via dei Tamerici 1/3  
Tel. 0541/956034-957884  
Fax 0541/956341  
47842 S. GIOVANNI IN M. (RN)  
e-mail: mtma@mtmarchetti.com  
http://www.mtmarchetti.com

PRODUZIONE MODULI ROTANTI



PAGINA NKM240-2-20