

ATTENZIONE - ATTENTION - ACHTUNG

- Verificare la tabella sottostante per possibile interferenza su alcuni modelli di macchine
- Please check the table below for possible interferences on some machine models
- Die untenstehende Tabelle unbedingt auf eventuelle Interferenzen auf eigenen Maschinenmodellen überprüfen

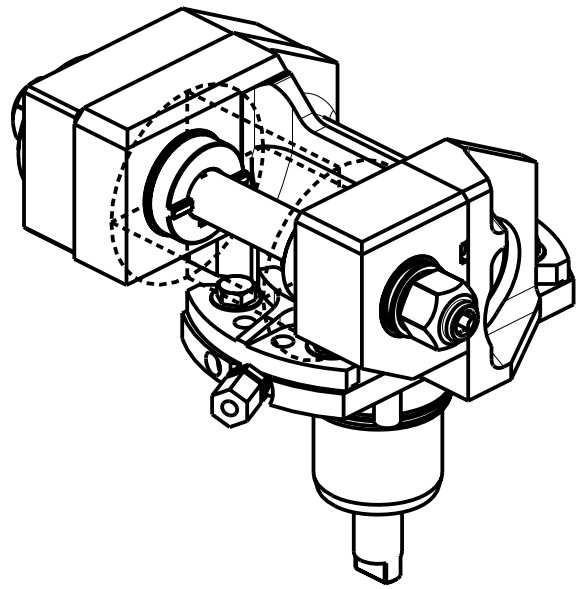

DOTAZIONI - SUPPLIED WITH - AUSSTATTUNG

mm / inch	- N°1 ALBERO + DISTANZIALI - N°1 SHAFT + SPACER - N°1 DORN + ABSTANDSSTUECK
-----------	---

PER ALBERI E DISTANZIALI VEDI PAG. TBL250-1-00
FOR SHAFT END SPACER SEE PAGE TBL250-1-00
FUER DORN UND ABSTANDSSTUECK SEITE TBL250-1-00

Cod. MT	Cod. NAKAMURA	I	RPM max	Lubrificazione int. Coolant through Innenkuehlung	Lubrificazione est. Ext. coolant Aussenkuehlung	D (mm)	D (Inch)	CHIAVI INCLUSE Keys included Schluessel inbegriffen		
								C HUB13	C HUB24	C HESL08
NKM0081100	-	1:1	6000		X	16-22-27-32	3/4"-1"-1 1/4"	C HUB13	C HUB24	C HESL08
NKM0082100	-	2:1	3000		X	16-22-27-32	3/4"-1"-1 1/4"	C HUB13	C HUB24	C HESL08

NAKAMURA-TOME

MOD: WT150/250 - WTW150 - WTS150 - NTM3 - SUPER NTJ - SUPER NTJX - SC250

MOD: TW 10M/MY/MM/MYY/MMYY-TW 20M/MY/MM/MYY/MMYY 16 ST.

MODULO MOTORIZZATO PORTACREATORE

Driven gear hobber

Angetriebenes Zahnradwalzfraes-Werkzeug

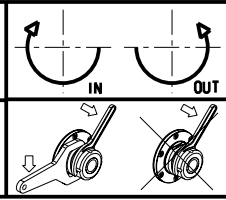

M.T. srl
Via dei Tamerici 1/3
Tel. 0541/956034-957884
Fax 0541/956341
47842 S. GIOVANNI IN M. (RN)
e-mail: mima@mtmarchetti.com
http://www.mtmarchetti.com

PRODUZIONE MODULI ROTANTI



PAGINA NKM340-2-00