

ATTENZIONE - ATTENTION - ACHTUNG

- Per lo smontaggio degli utensili utilizzare sempre la chiave di contrasto come indicato nel manuale d'uso.
- For disassembly of the tools use always the contrast key as mentioned in the user instructions.
- Fuer das Abmontieren der Werkzeuge immer den Gegenschlüssel benutzen wie in der Bedienungsanleitung erwaeht.

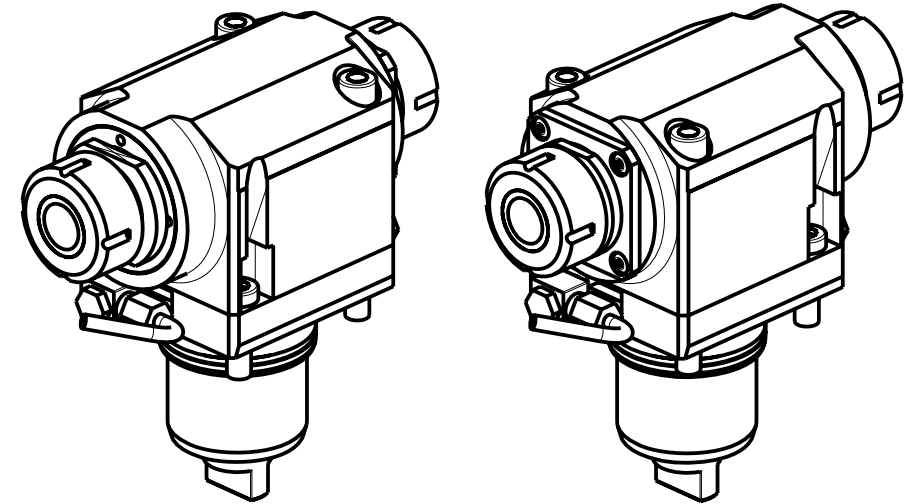
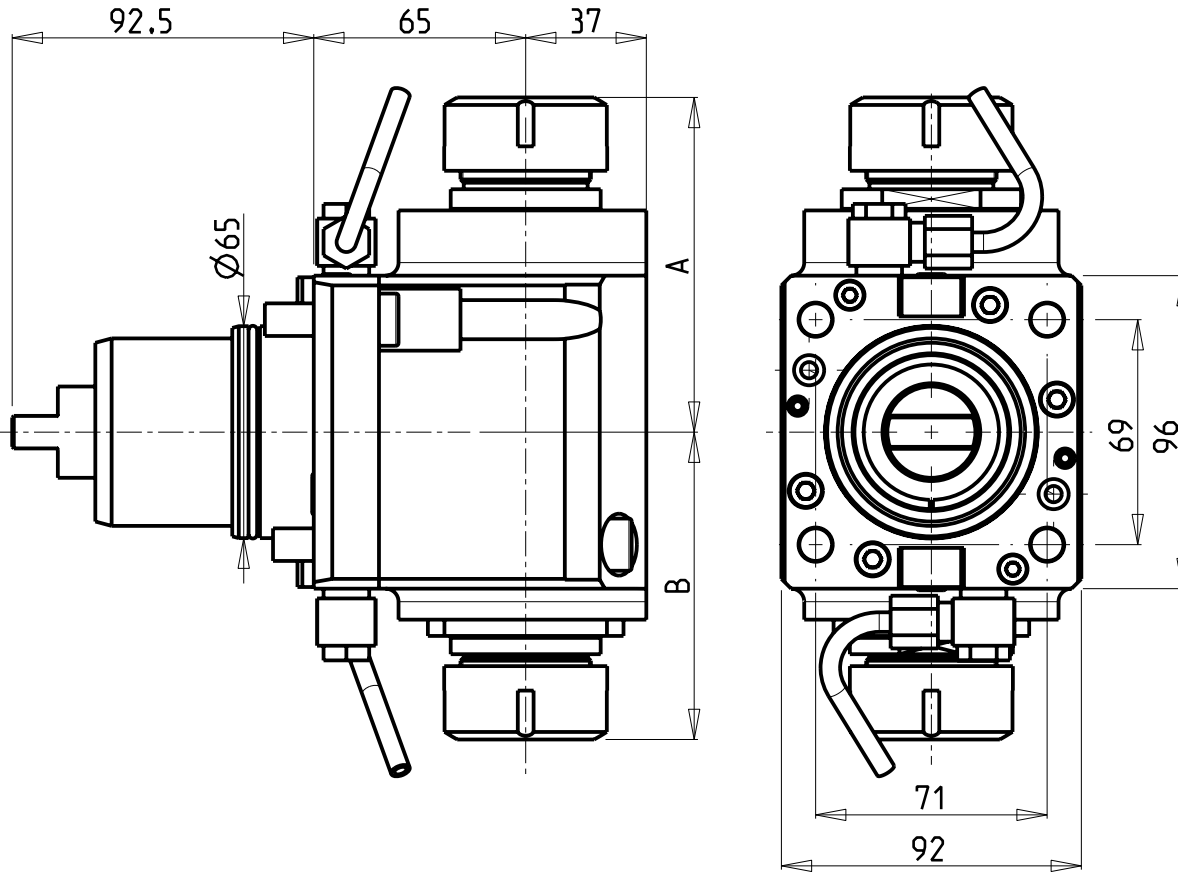

Cod. MT	Cod. NAKAMURA	Mandrino Spindle Spindel	I	RPM	Reversibile lato mandrino/contromandrino Reversible sub/main spindle side Umkehrbare Spindel-seite/ Gegenspindel-seite	Lubrificazione int. Coolant through Innenkuehlung	Lubrificazione est. Ext. coolant Ausseinkuehlung	A	B	CHIAVI NON INCLUDE Keys not included Schlüssel nicht einbegriffen		
NKM0600232	-	ER32+ER32	1:1	6000	X		X	102.66	94.26	CHSTER32	CHUB46	NEW

NAKAMURA-TOME

MOD: Super Mill WT150/WY250/SC200L

MODULO MOTORIZZATO ASSIALE BISPORGENTE H=65

Opposite face axial driven tool with 65 mm interaxis

Axial angetriebenes Werkzeug halb vorspringend int. 65 mm

M.T. srl

Via dei Tamerici 1/3
Tel. 0541/956034-957884
Fax 0541/956341
47842 S. GIOVANNI IN M. (RN)
e-mail: mtma@mtmarchetti.com
http://www.mtmarchetti.com

PRODUZIONE MODULI ROTANTI



PAGINA NKM240-4-10